

TYPE "I" CATCH BASIN

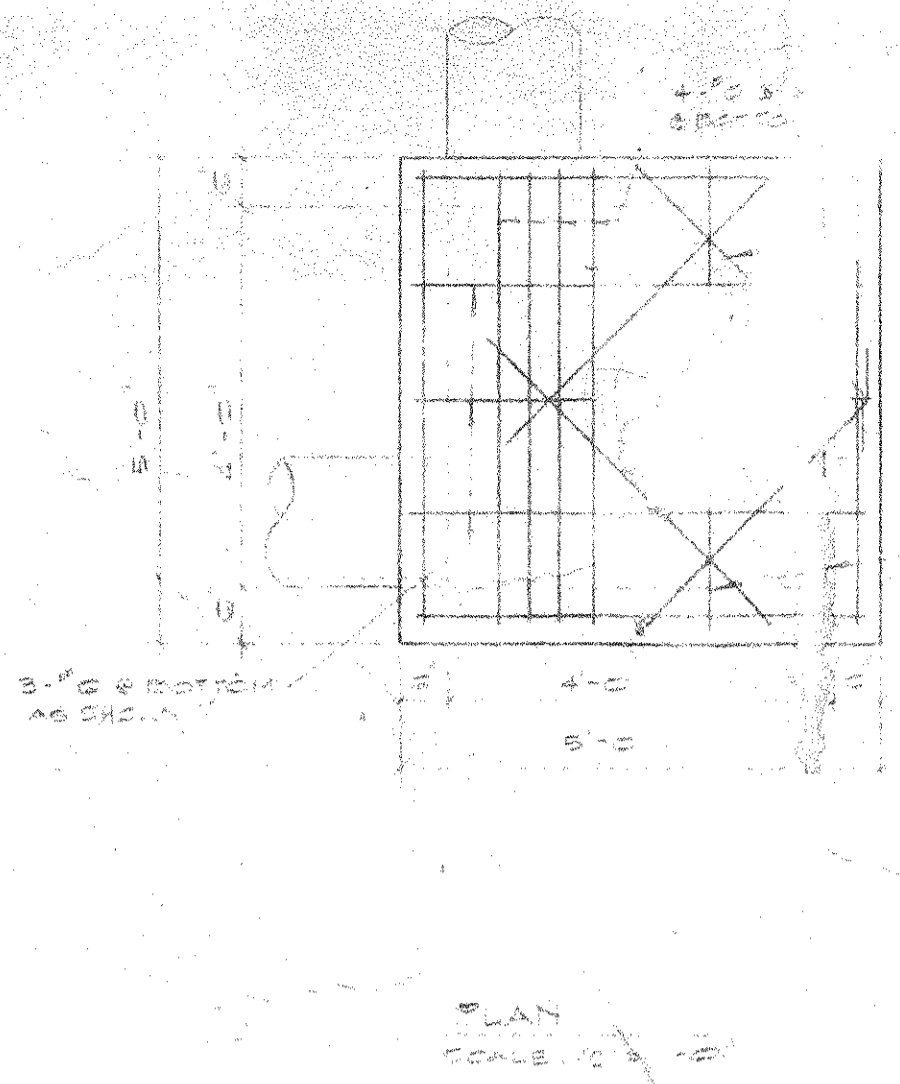

STORM DRAIN MANHOLE DETAIL

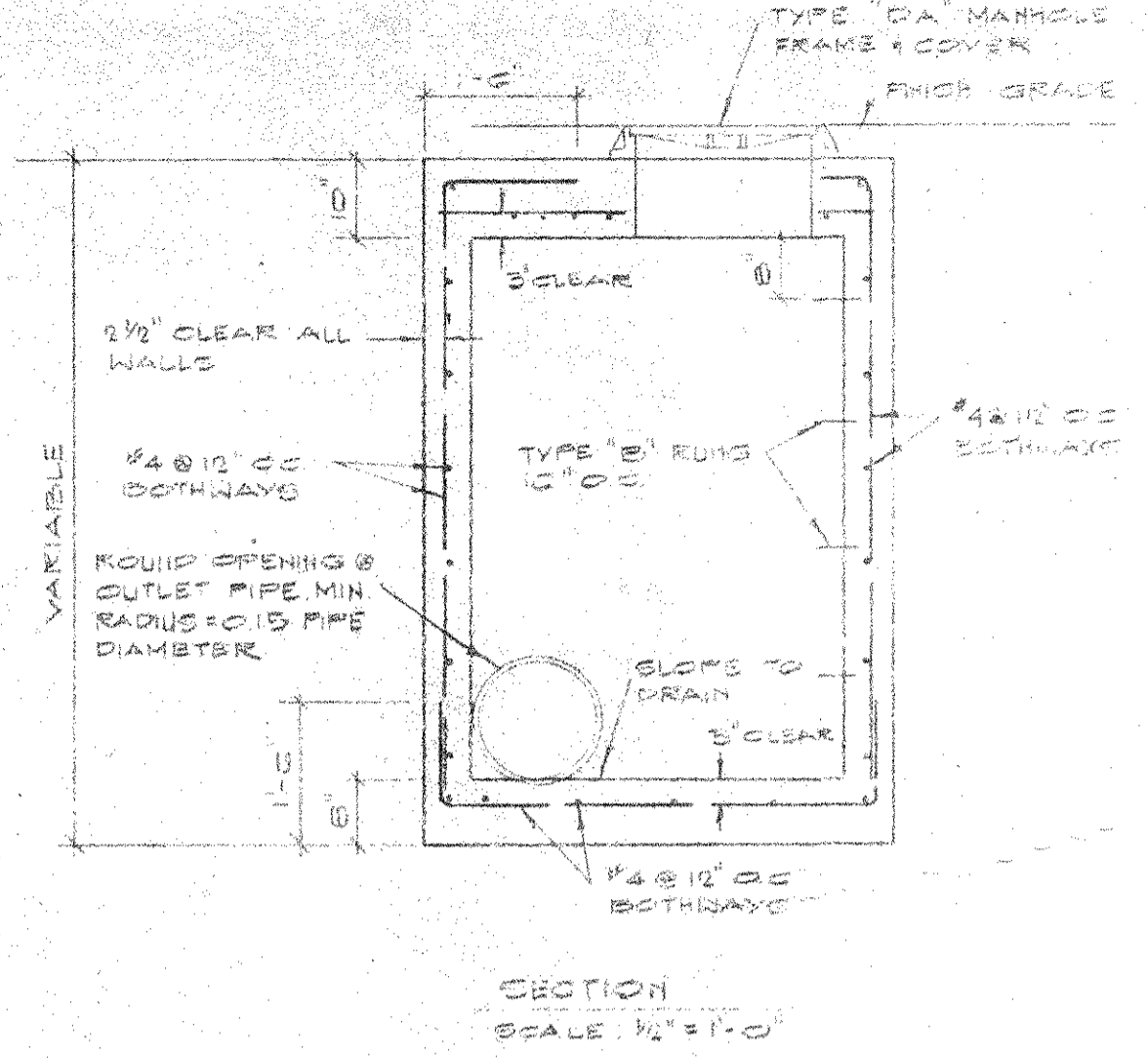
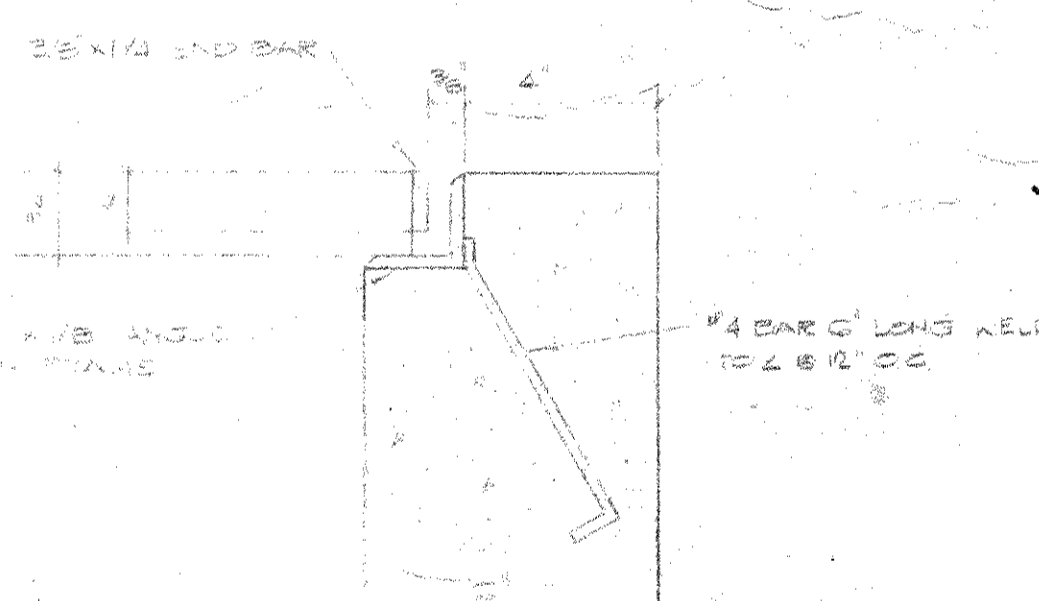
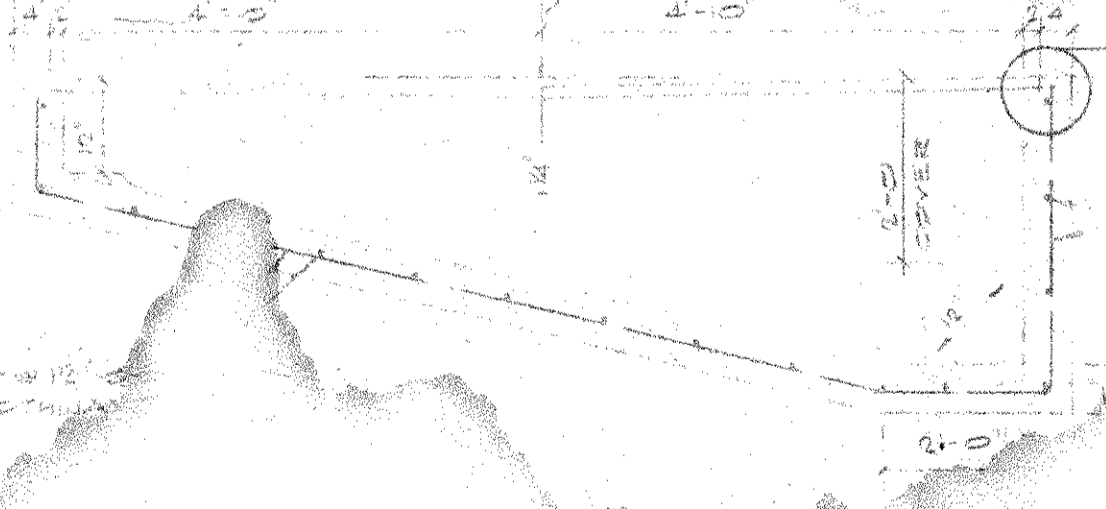
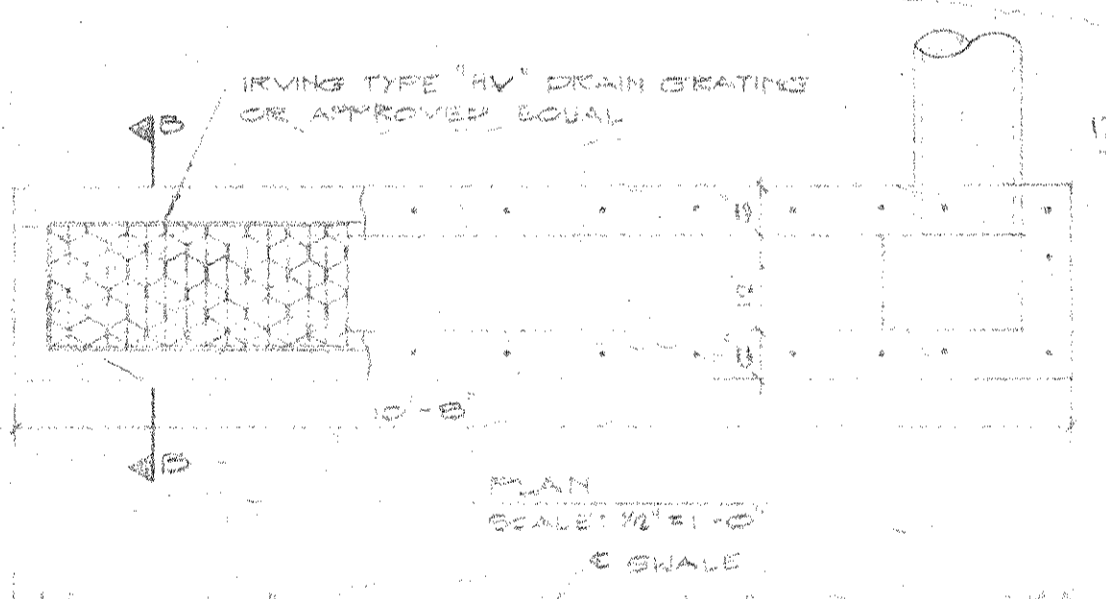
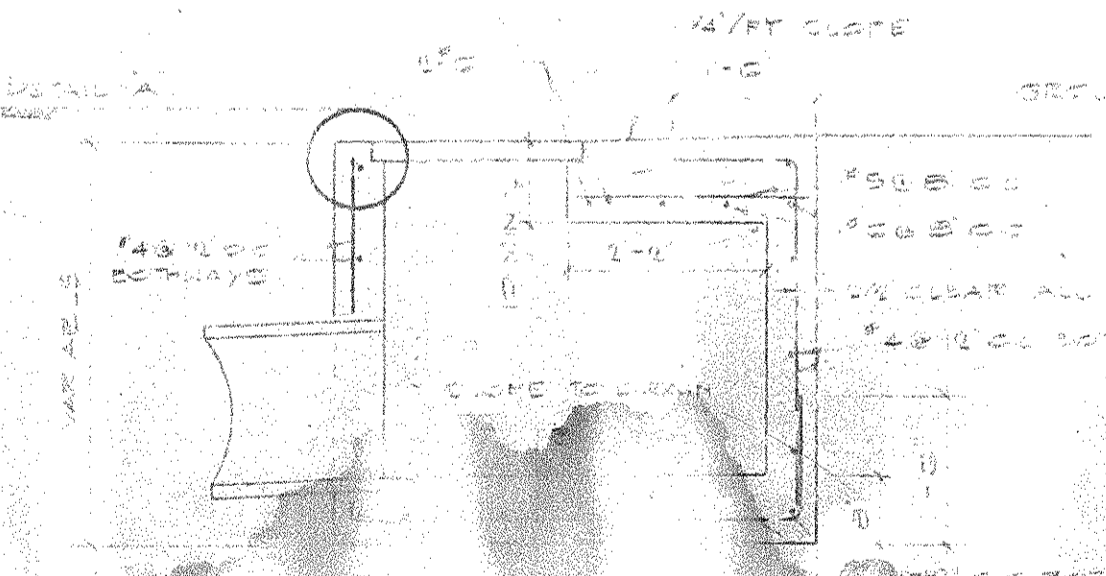
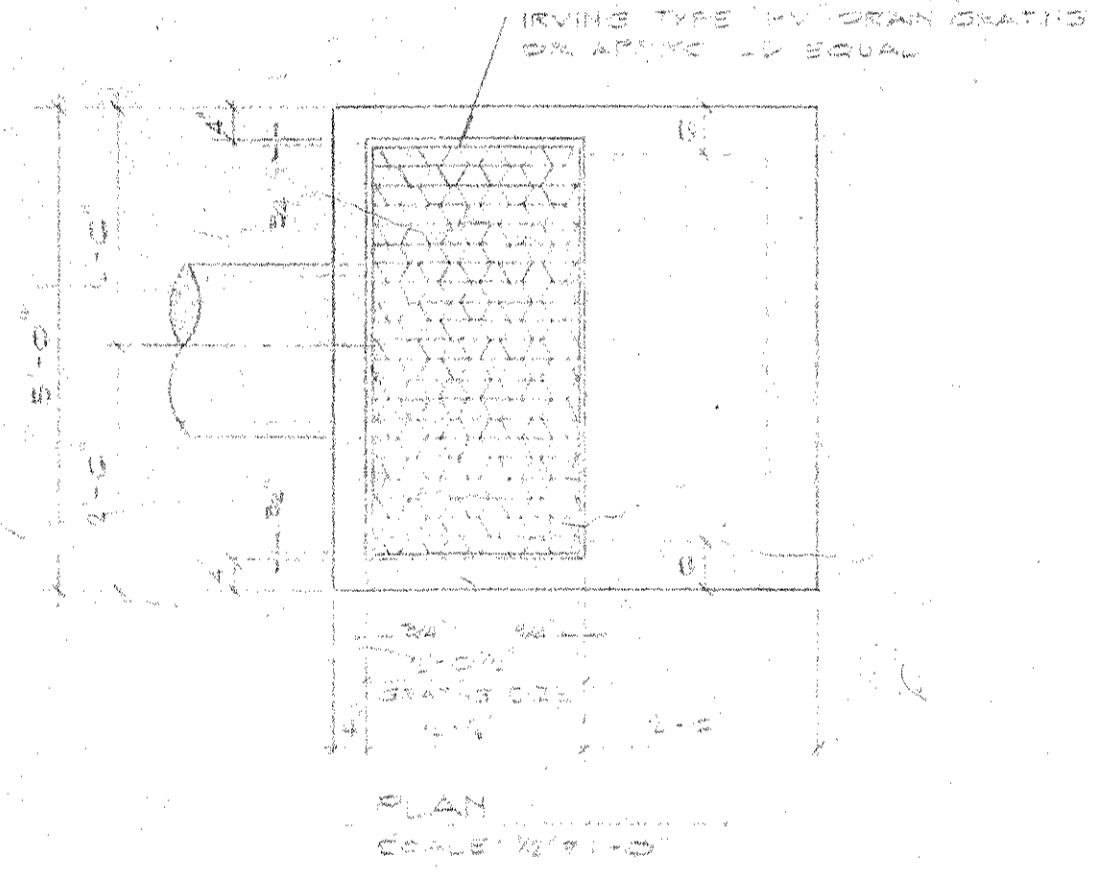

Wailea

ENGINEERING ARCHITECTURE

1001 KALANANAKUI AVENUE, SUITE 1000, HONOLULU, HAWAII 96813

PHONE: (808) 943-2222

FAX: (808) 943-2223

WWW.WAILEA.COM

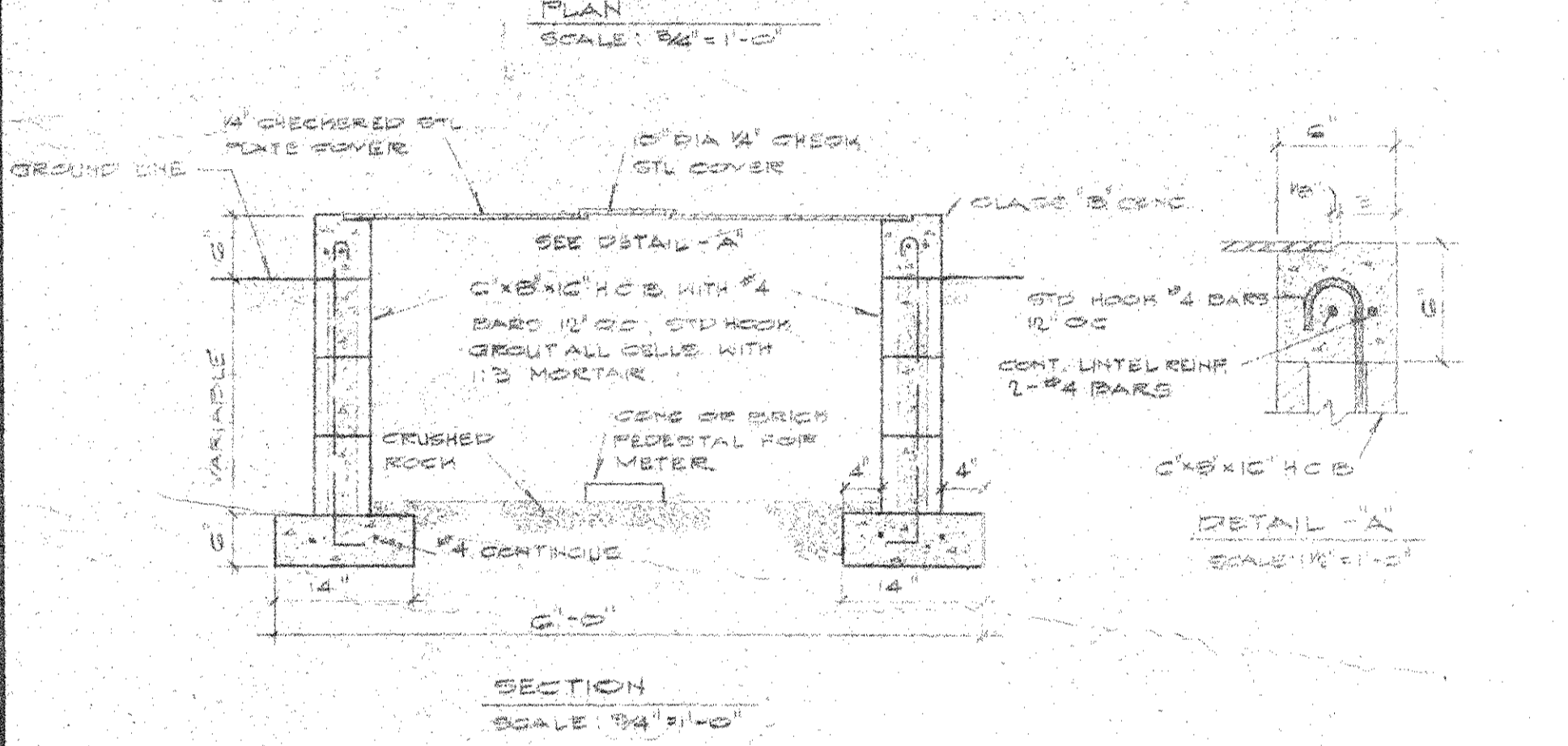
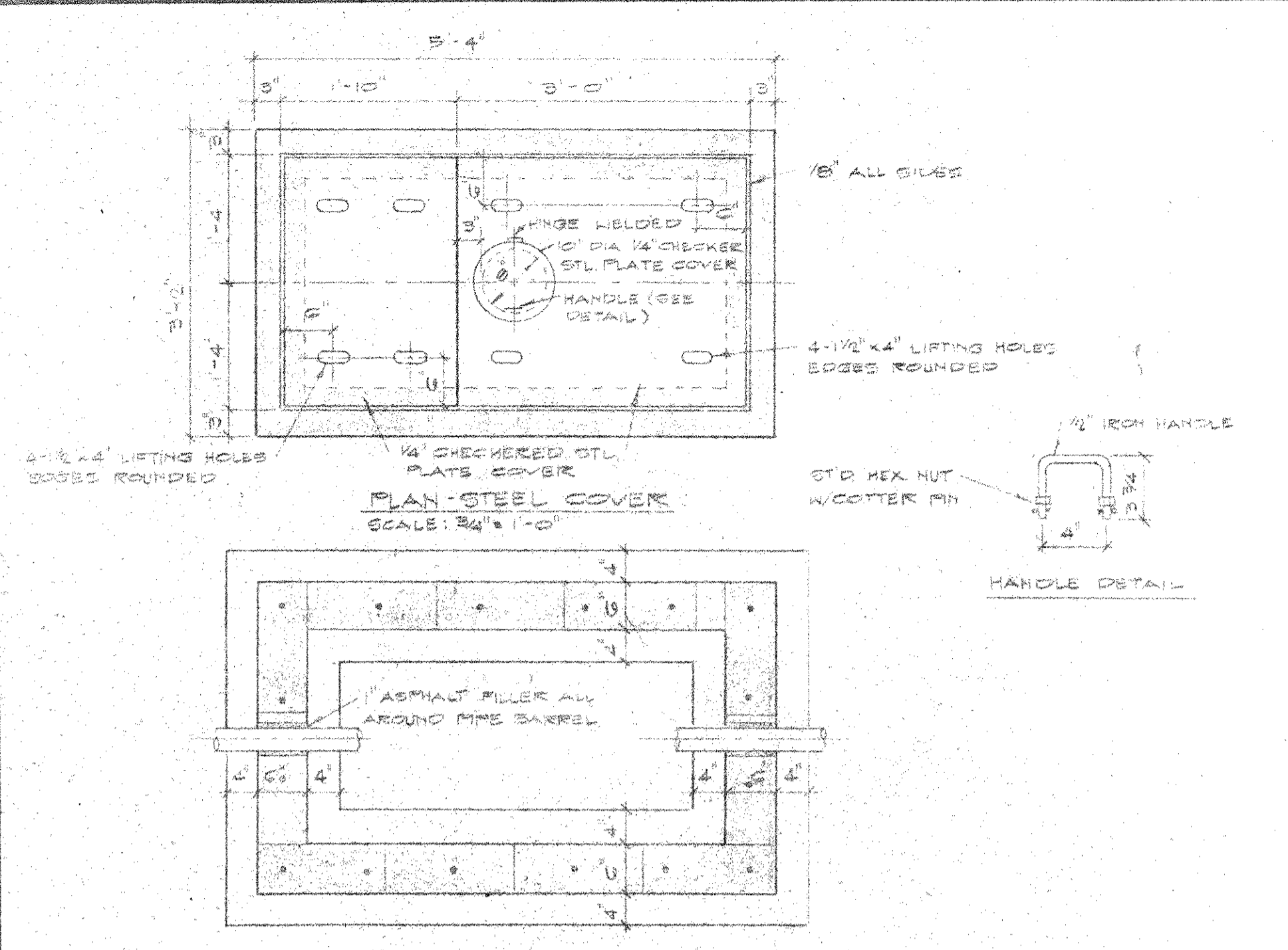

METER BOX DETAIL

CONCRETE REACTION BLOCK BEARING AREA
ASSUMED BEARING VALUE 1,000 LB/SQ. FT.

FITTING	12"	8"	6"
1 1/2" BEND	2 1/2 SQ. FT.	1 SQ. FT.	3/4 SQ. FT.
1 1/4" BEND	5 SQ. FT.	2 1/4 SQ. FT.	1 1/4 SQ. FT.
1" BEND	10 SQ. FT.	4 1/2 SQ. FT.	2 1/2 SQ. FT.
3/4" BEND	18 SQ. FT.	8 SQ. FT.	4 1/2 SQ. FT.
FLUSH TEE	14 SQ. FT.	6 1/2 SQ. FT.	3 1/2 SQ. FT.

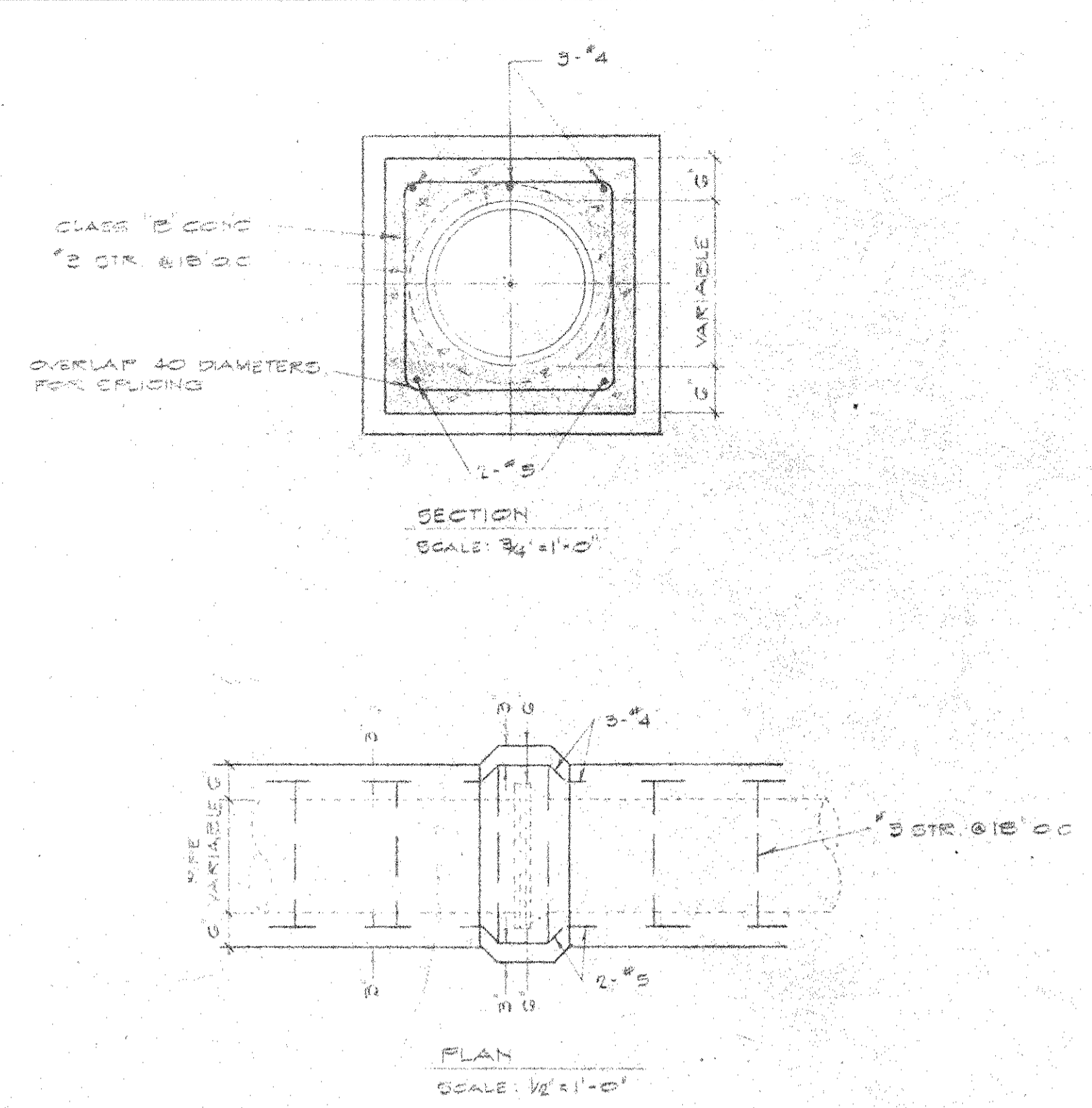

CONCRETE JACKET DETAIL

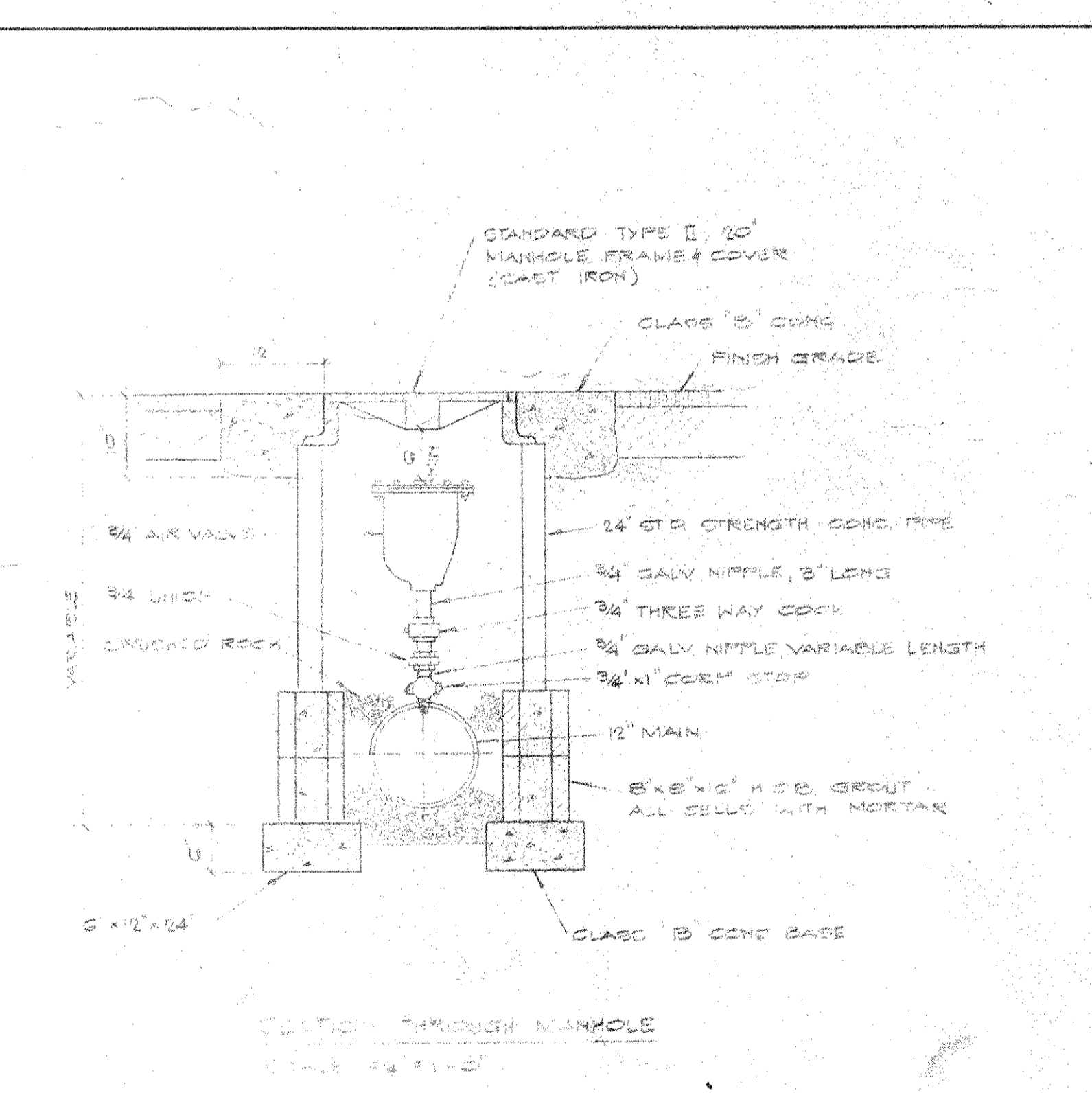

SECTION THROUGH MANHOLE

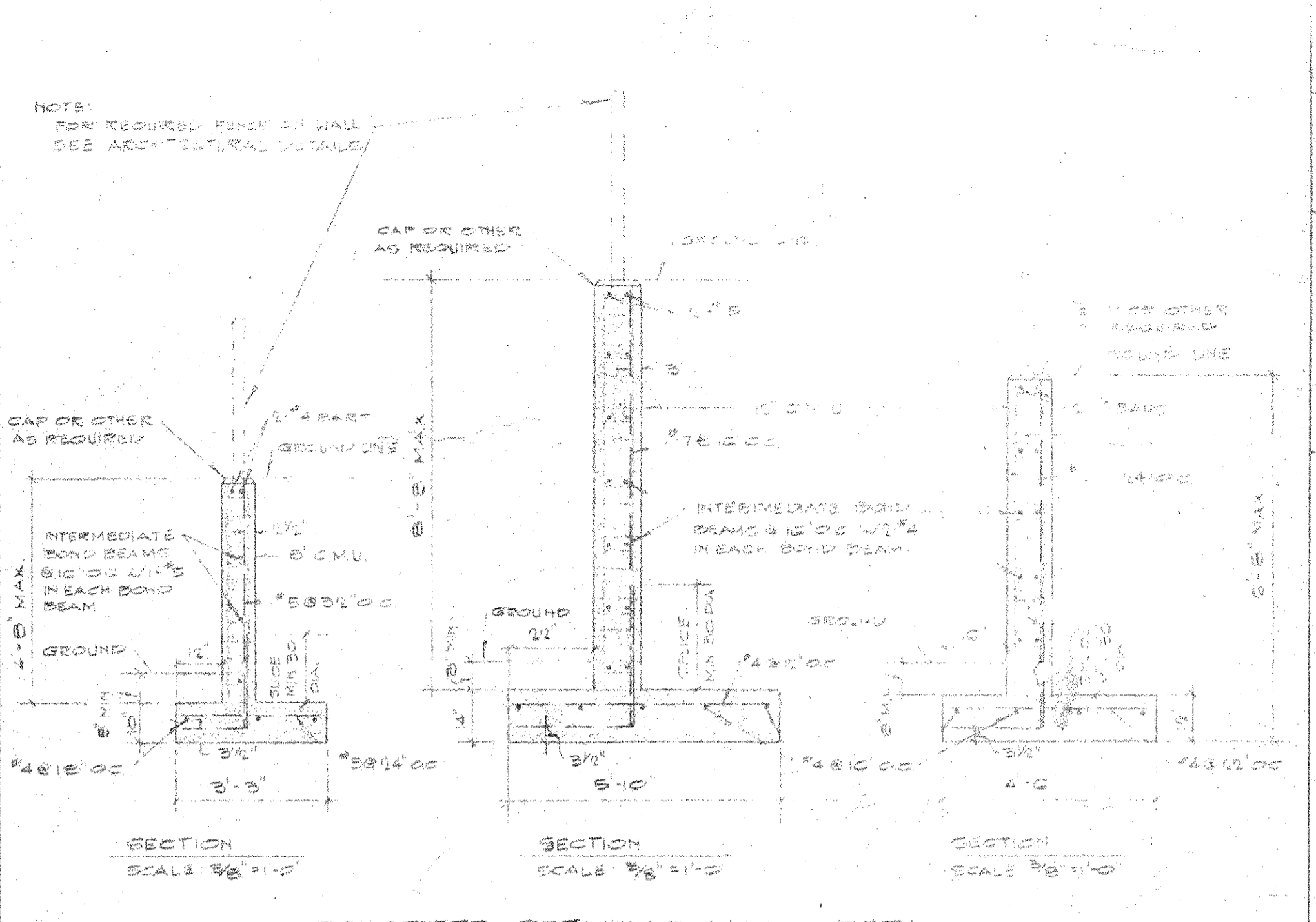

CONCRETE RETAINING WALL DETAIL

NOTE: CONCRETE RETAINING WALLS MAY BE USED AS ASSURABLE ALTERNATE AS APPROVED BY THE ENGINEER.

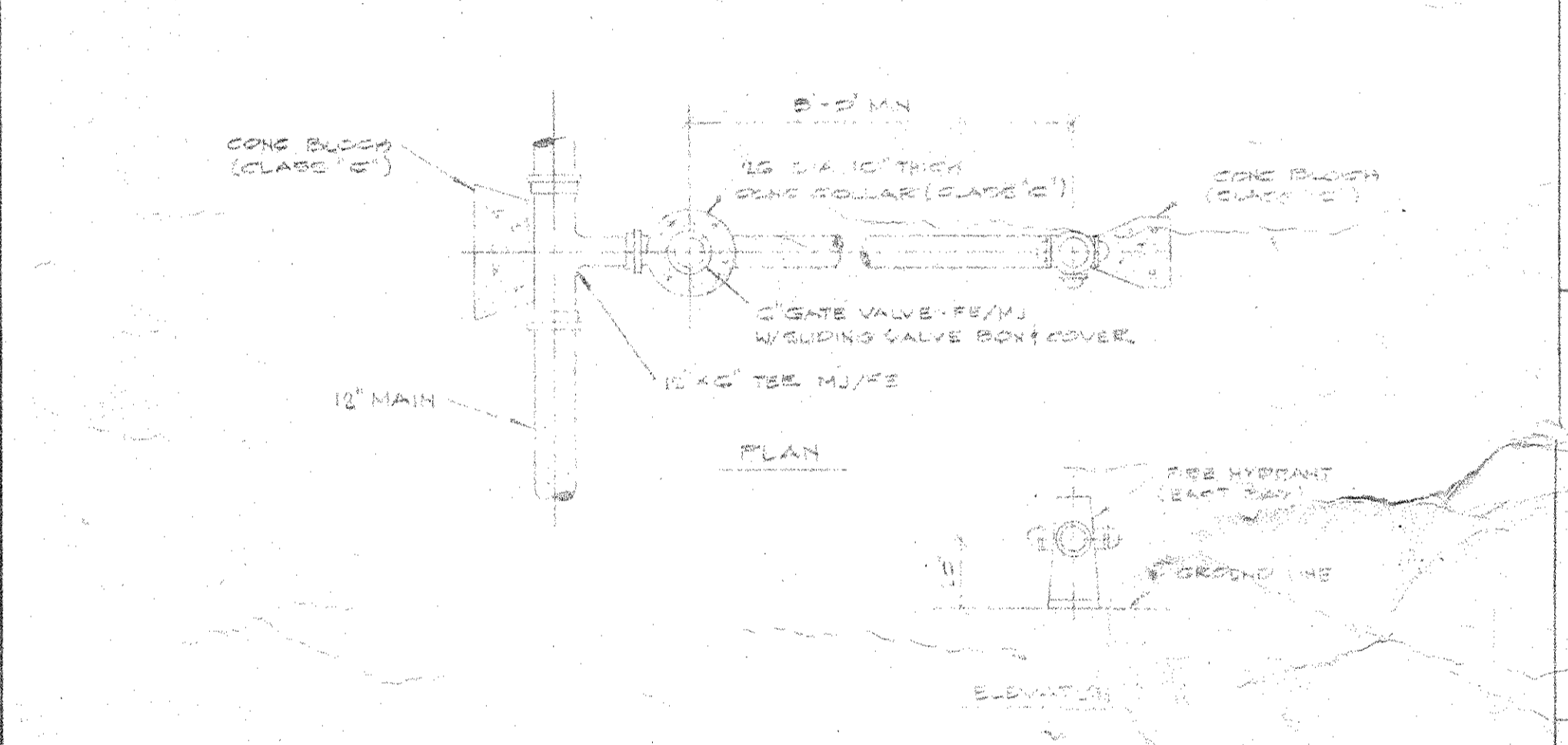

FIRE HYDRANT DETAIL

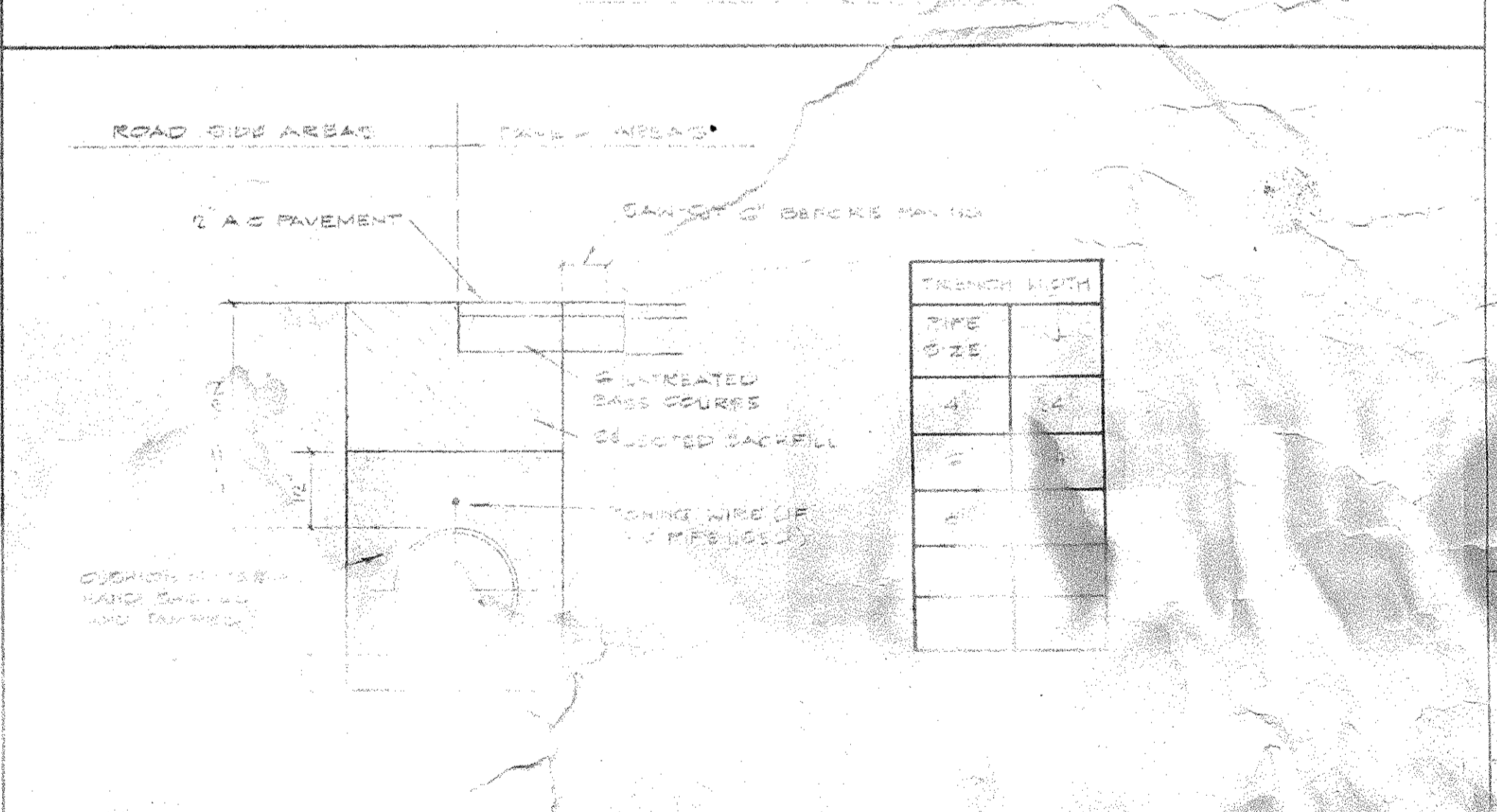

DESIGNED BY	DATE
CHECKED BY	DATE
IN CHARGE	DATE
CONSTRUCTION	DATE
FINAL REVIEW	DATE

Norman Saito Engineering Consultants, Inc.
Civil Engineers
P.O. Box L
Waikuku, Hawaii 96793
(808) 244-5278

Esterick Homsey Dodge and Davis
Architects and Planners
120 Green Street
San Francisco, California 94111
(415) 421-1924

Thomas R. Rivette, AIA
Professional Engineer
120 Green Street
San Francisco, California 94111
(415) 421-1924

Wailea
KEAWAKAPU BEACH VILLAGE
MAUI, HAWAII

TMK: 2-1-8-Bor-42
SHEET NO. 10
GENERAL NOTES
RETAINING WALL
SCALE: AS SHOWN

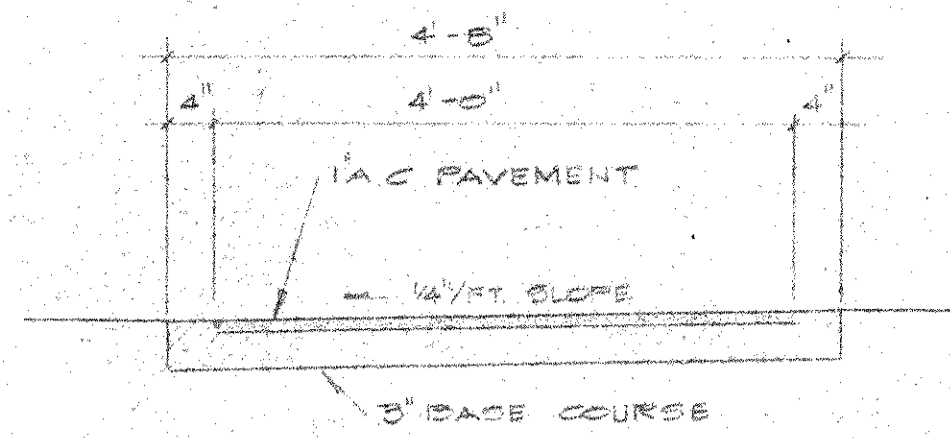

TYPICAL SECTION
SCALE: 3/8" = 1'-0"

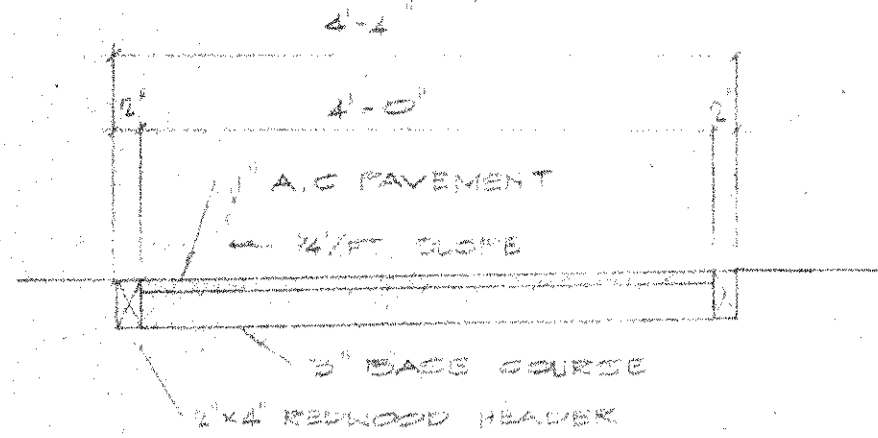

ALTERNATE "A"
SCALE: 3/8" = 1'-0"

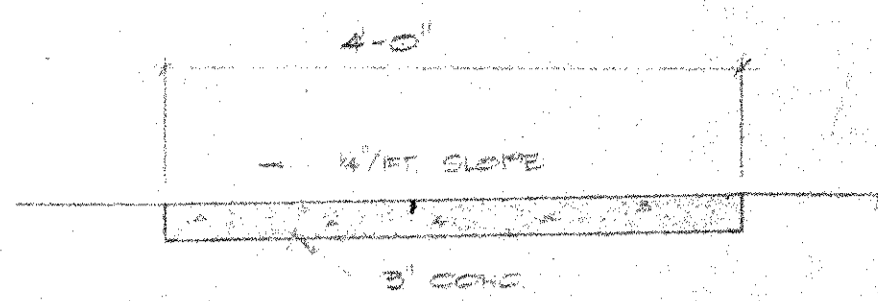

ALTERNATE "B"
SCALE: 3/8" = 1'-0"

BROOM FINISH
SCORE TRANSVERSELY @ 5'
INTERVALS

FOOT PATH DETAIL

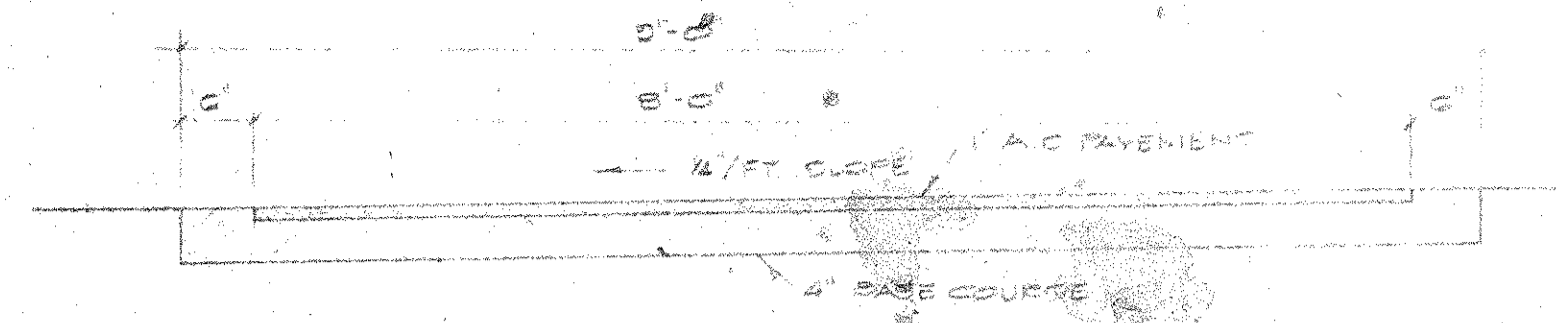

SECTION
SCALE: 3/8" = 1'-0"

CART PATH DETAIL

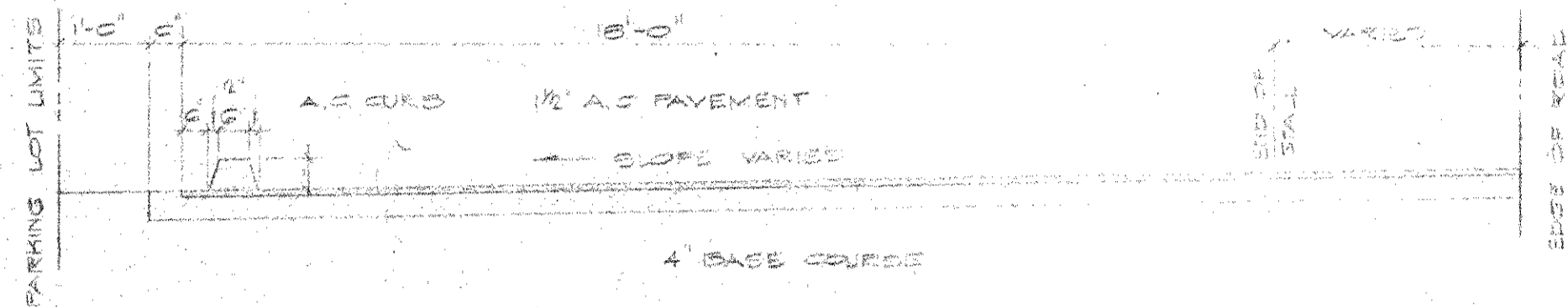

TYPICAL SECTION
SCALE: 3/8" = 1'-0"

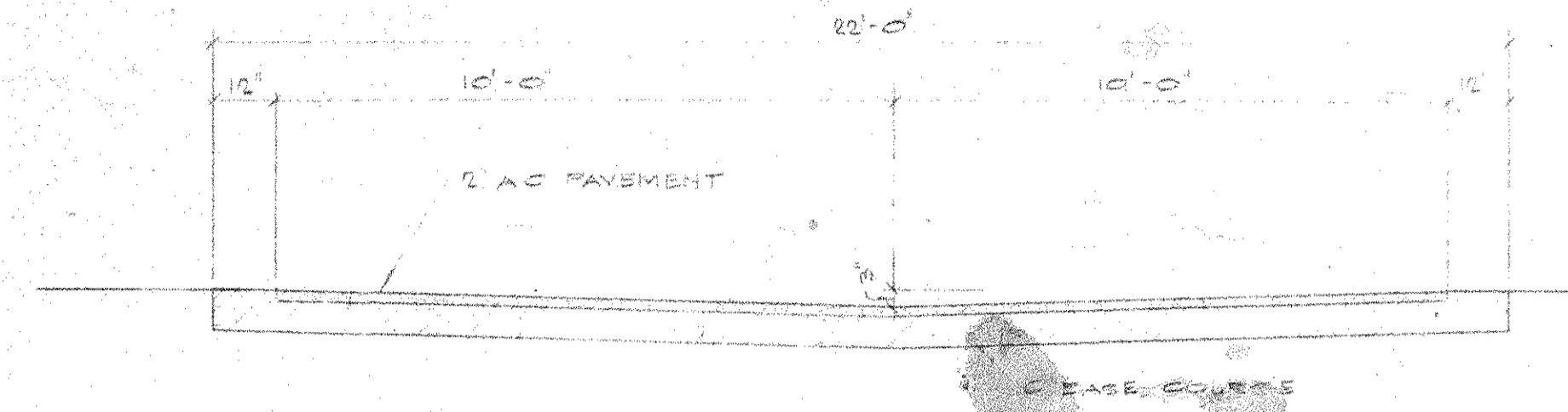

TYPICAL SECTION
SCALE: 3/8" = 1'-0"

ROAD SECTION DETAIL

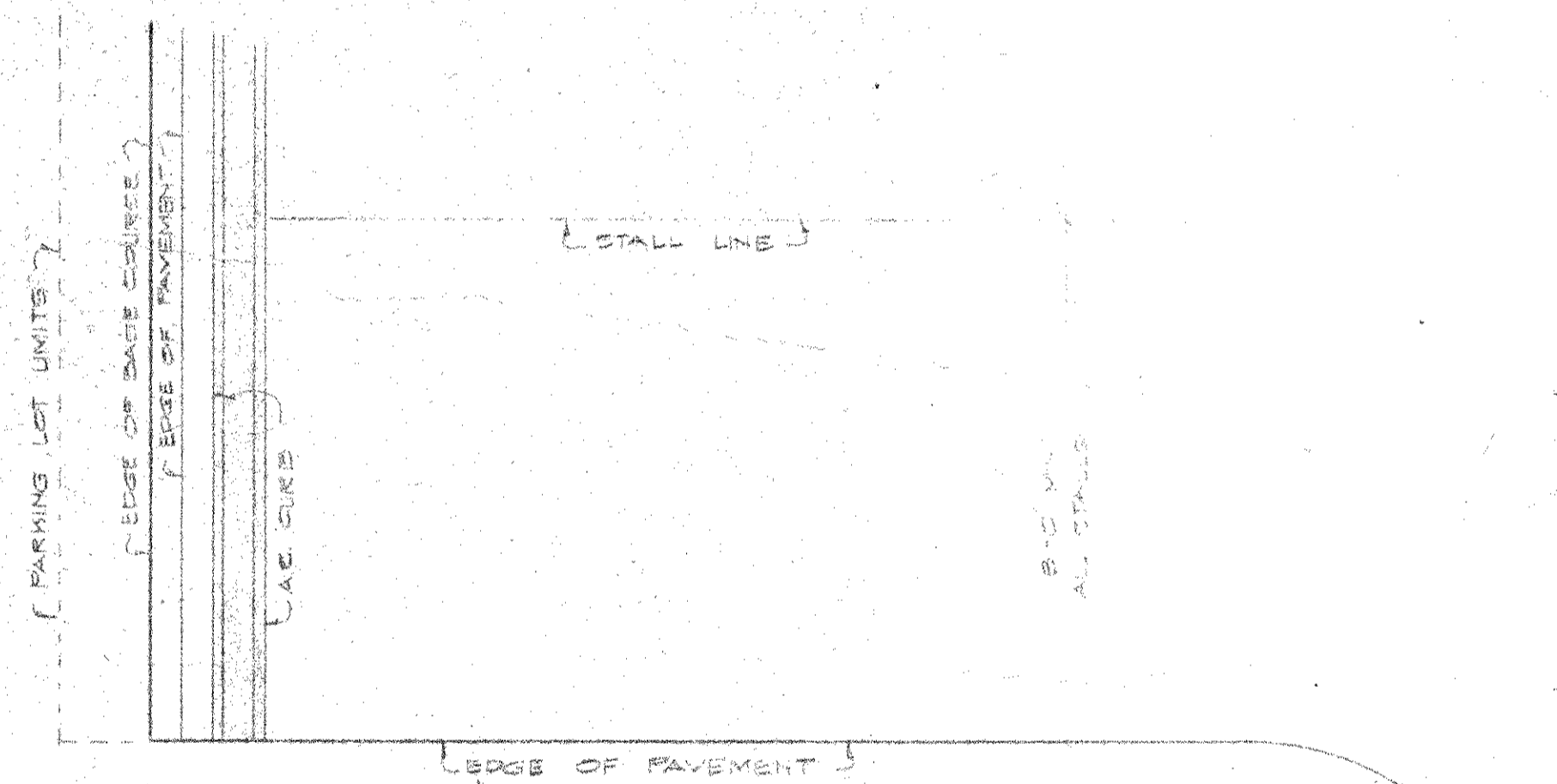

PARKING LOT STALL DETAIL

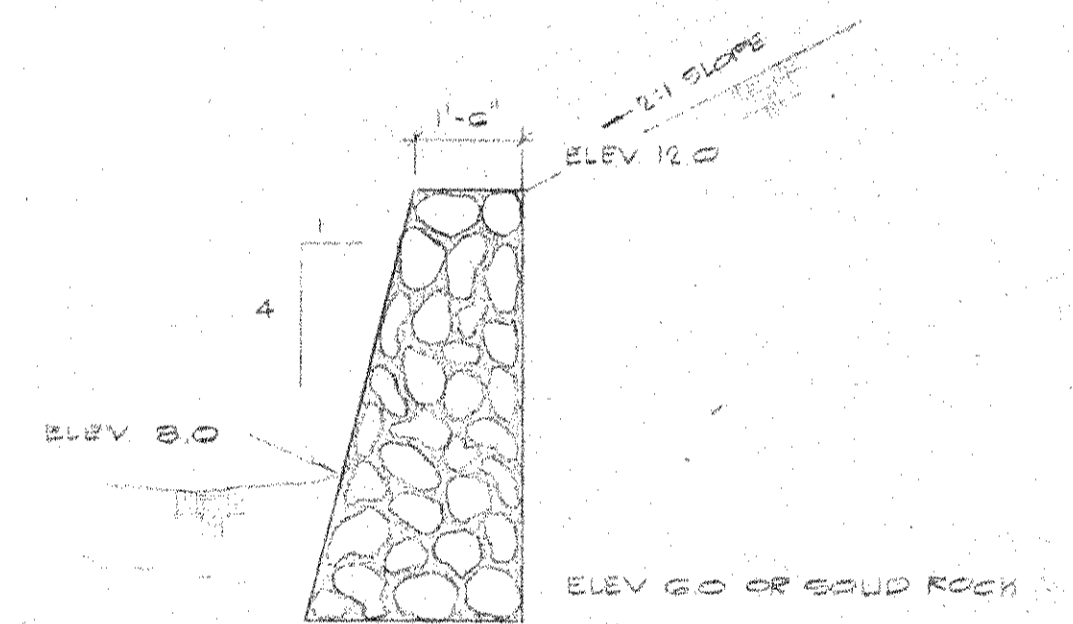

SECTION
SCALE: 3/8" = 1'-0"

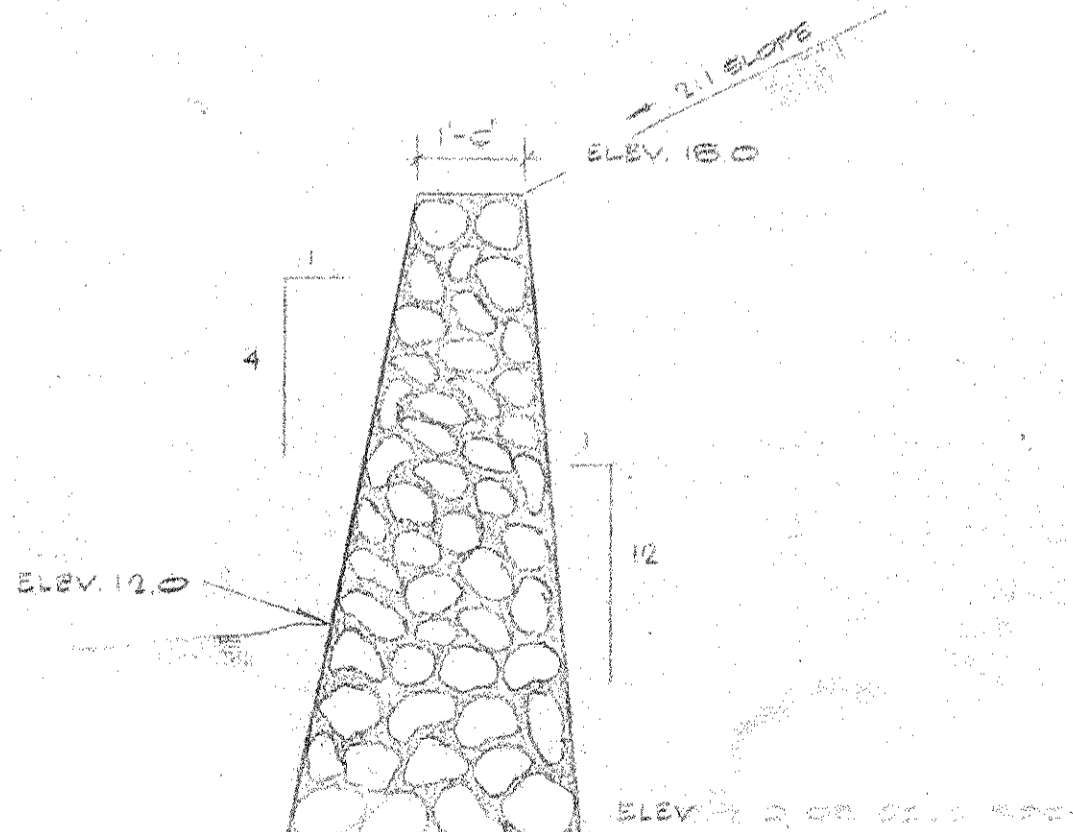

SECTION
SCALE: 3/8" = 1'-0"

CONC. ROCK RETAINING WALL ALTERNATE
FOR USE AT CURB AREA FOR ROAD WALL
DETAIL FOR USE AS A CURB SIDE WALK

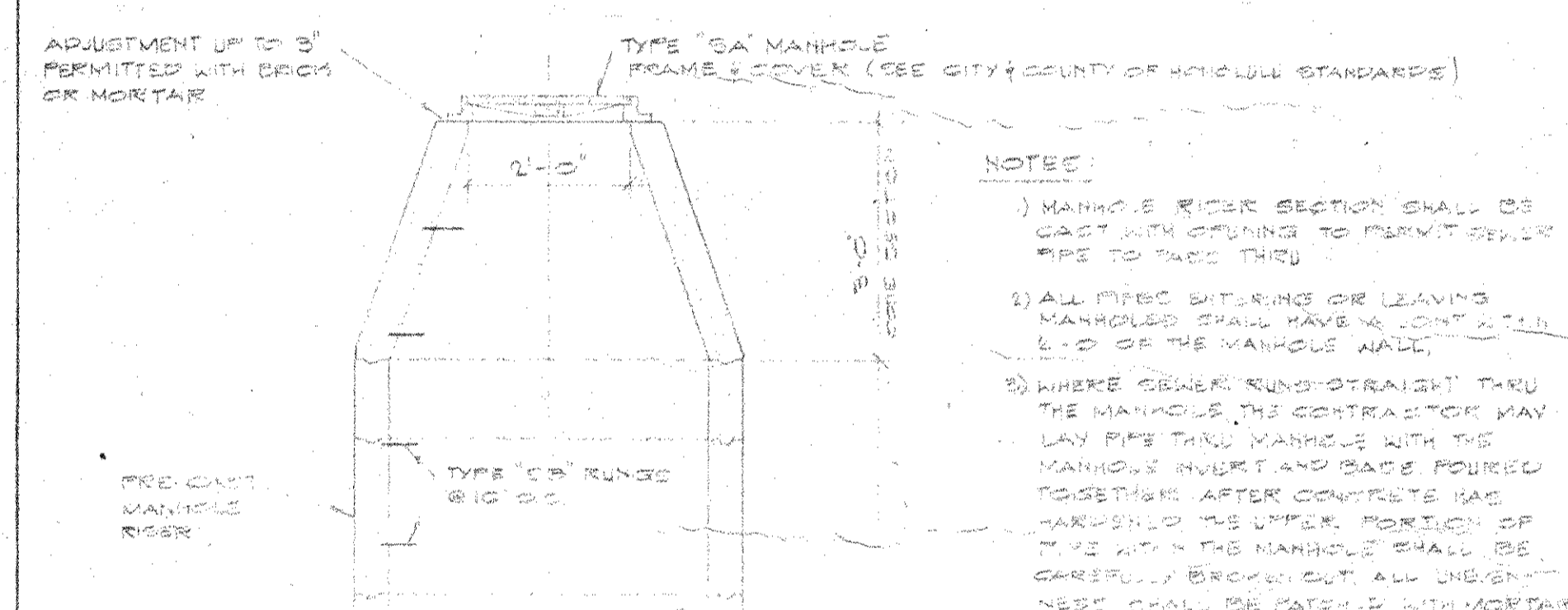

SECTION
SCALE: 3/8" = 1'-0"

- NOTES:
- 1) MANHOLE RIGID SECTION SHALL BE CAST WITH COUPLING TO PERMIT OTHER PIPE TO PASS THRU
 - 2) ALL PIPED BITUMING OR LEAVING MANHOLES SHALL HAVE A JOINT AT THE END OF THE MANHOLE WALL
 - 3) WHERE GENERAL RUND STRAIGHT TANK THE MANHOLE THE CONTRACTOR MAY LAY PIPE THRU MANHOLE WITH THE MANHOLE INVERT AND BARS FORMED TOGETHER AFTER CONCRETE HAS HARDENED THE UPPER PORTION OF PIPE WITH THE MANHOLE SHALL BE CAREFULLY BROKEN OUT ALL UNDERNESS SHALL BE PATCHED WITH MORTAR

GENERAL MANHOLE DETAIL

DATE	7-24
BY	...
CHECKED	...
APPROVED	...
PROJECT	...
CONSTRUCTION	...
DATE	...
BY	...
CHECKED	...
APPROVED	...

Norman Saito Engineering Consultants, Inc.
Civil Engineers
P. O. Box L
Wailuku, Hawaii 96793
(808) 244-5278

Edward, Norman Dodge and Davis
Architects and Planners
120 Cedar Street
San Francisco, California 94111
(415) 421-1224

Hans Bieche, AIA
Architect Associated
Kahului, Hawaii 96732

Wailea
KAMAHELO BEACH VILLAGE
MAUI, HAWAII
WAILAIA DEVELOPMENT COMPANY
822 BISHOP ST., HONOLULU, HAWAII 96813

TMK: 2-1-8:Por 42
TITLE
TYPICAL DETAILS
ROAD, PARKING
PATHS, SEWER
DRY WALL
SCALE
AS SHOWN
SHEET

TRUE NORTH
SCALE: 1"=40'

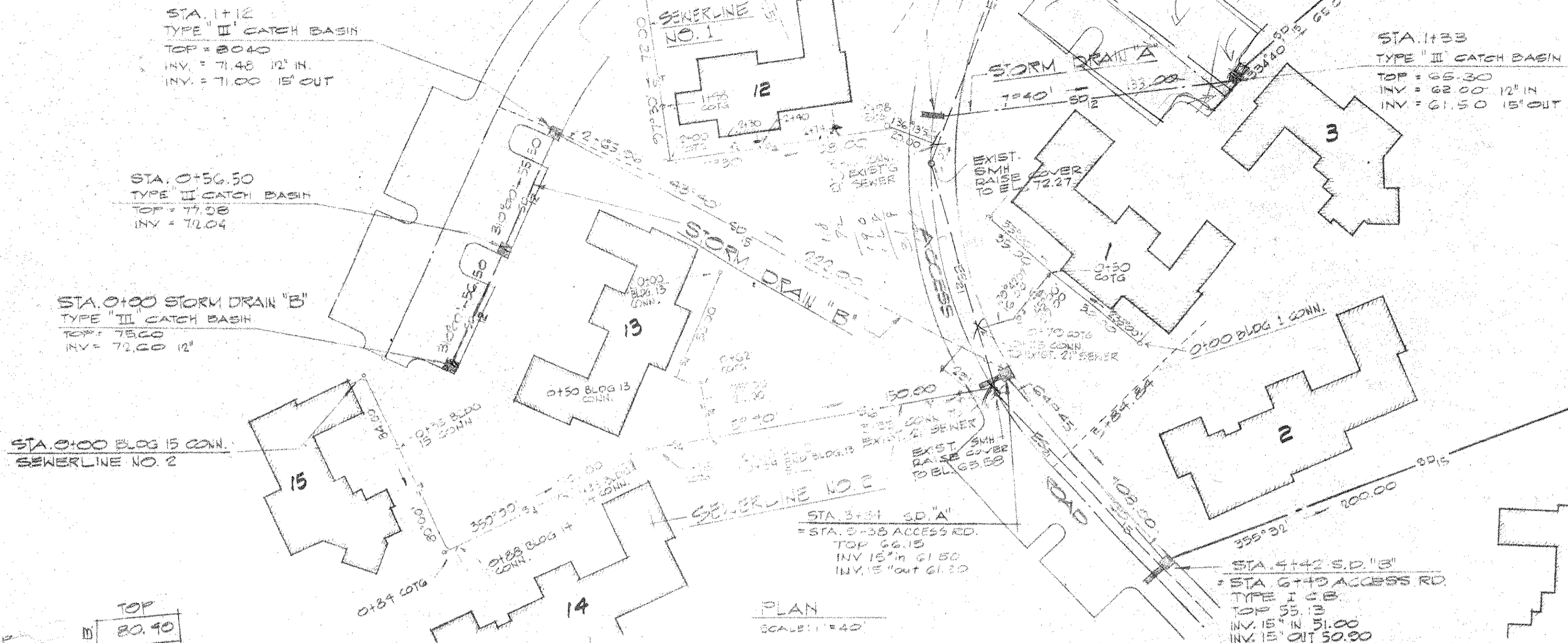

REVISED 7/22/74 AS DICTATED
BY PRE-CONSTRUCTION MEETING
OF 7/11/74

REVISED FOR CONSTRUCTION
6/24/74

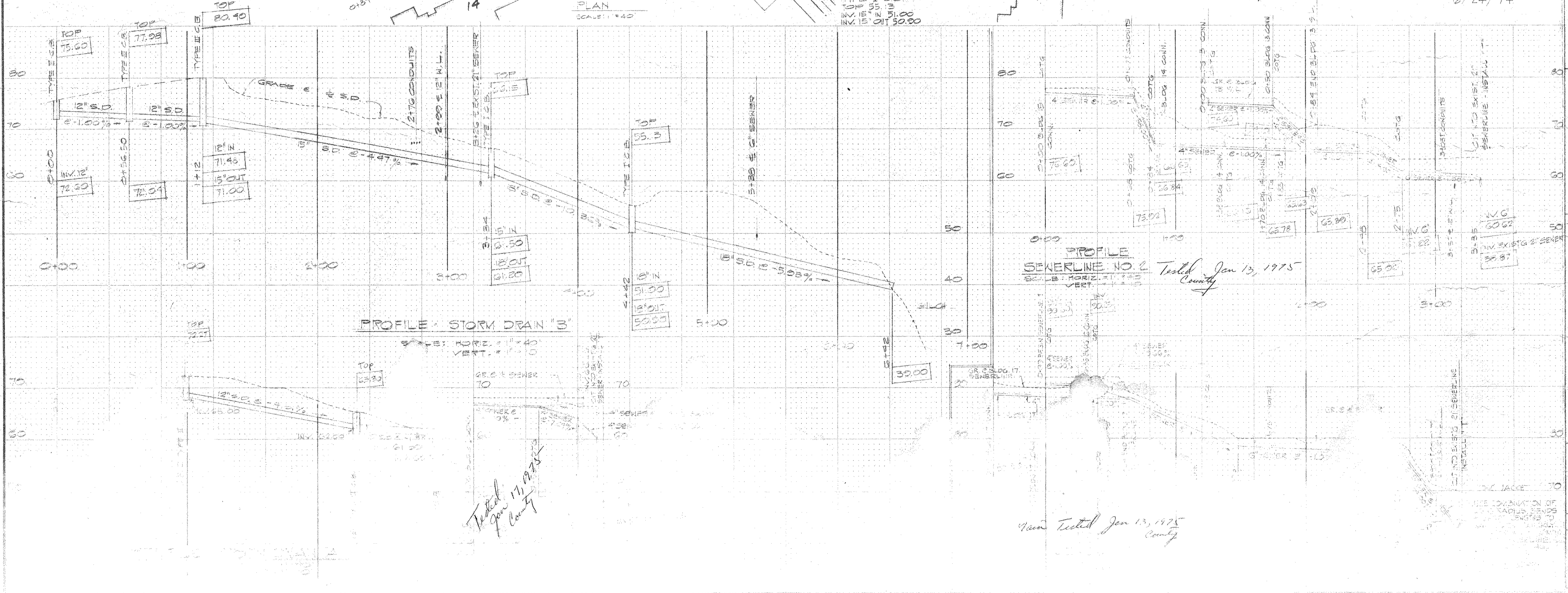

DESIGNED BY	DATE
CHECKED BY	DATE
APPROVED BY	DATE
CONSTRUCTION	DATE
FINAL REVIEW	DATE

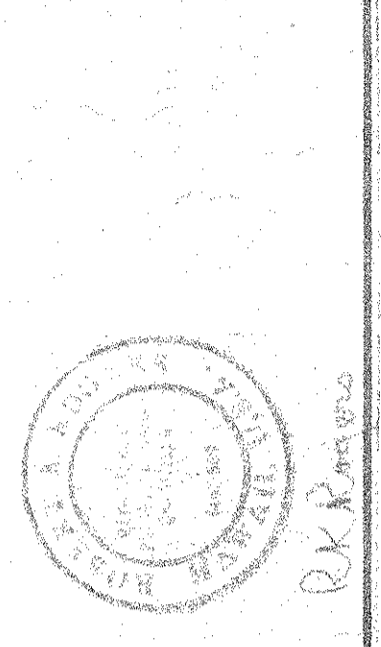

Norman Saito Engineering Consultants, Inc.
Civil Engineers
P.O. Box L
Waikiki, Hawaii 96793
(808) 244-5278

Eberick Homsy Dodge and Davis
Architects and Planners
120 Green Street
San Francisco, California 94111
(415) 421-1924

Hana Reicks, AIA
Architect Associated
Kahului, Hawaii 96729

Wailea
KAWAKAPU BEACH VILLAGE
WAILEA DEVELOPMENT COMPANY
622 BISHOP ST., HONOLULU, HAWAII 96813

TMK: 2-1-8-Por 42
Title
PLAN & PROFILE
STORM DRAIN AND
SEWER LINE
SEEVING BLDGS
& 112 THRU 17
SCALE
AS SHOWN
SHEET

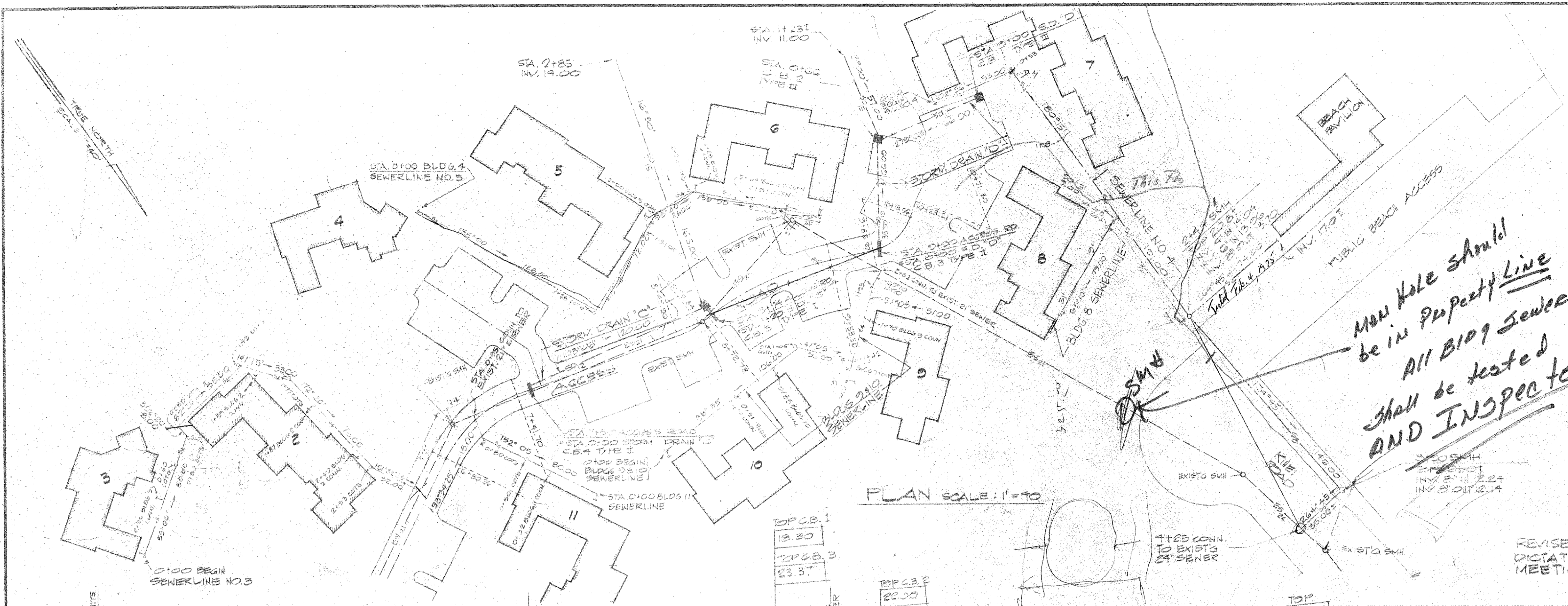

Man Hole should be in Property Line
 All Bldg Sewer shall be tested AND INSPECTED

NOTE:
 WE Require Between Bldgs, Clean outs, shall be every 50'-0" OR MAN HOLES 300 ft.
 J-M Ring TITE PVC Gravity Sewer Pipe shall be size's 4, 6, 8, 10, 12, fittings shall be MED. Sweep elbows, 45 degree elbows combination elbows AND 1/2 BEND, PLUGS AND ADAPTERS

REVISED 7/22/74 AS DICTATED BY PRE-CONSTRUCTION MEETING OF 7/11/74
 REVISED FOR CONSTRUCTION 6/24/74

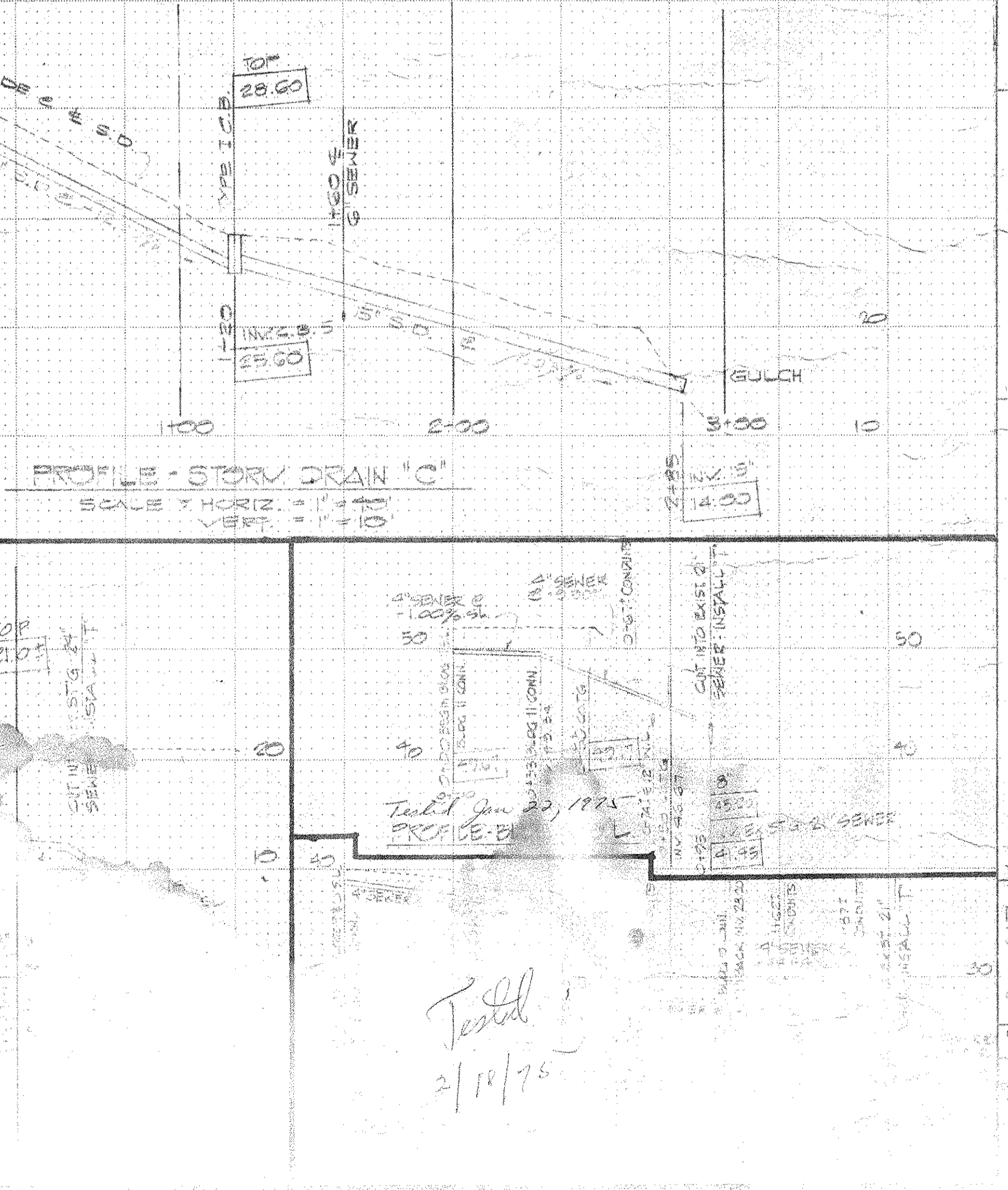
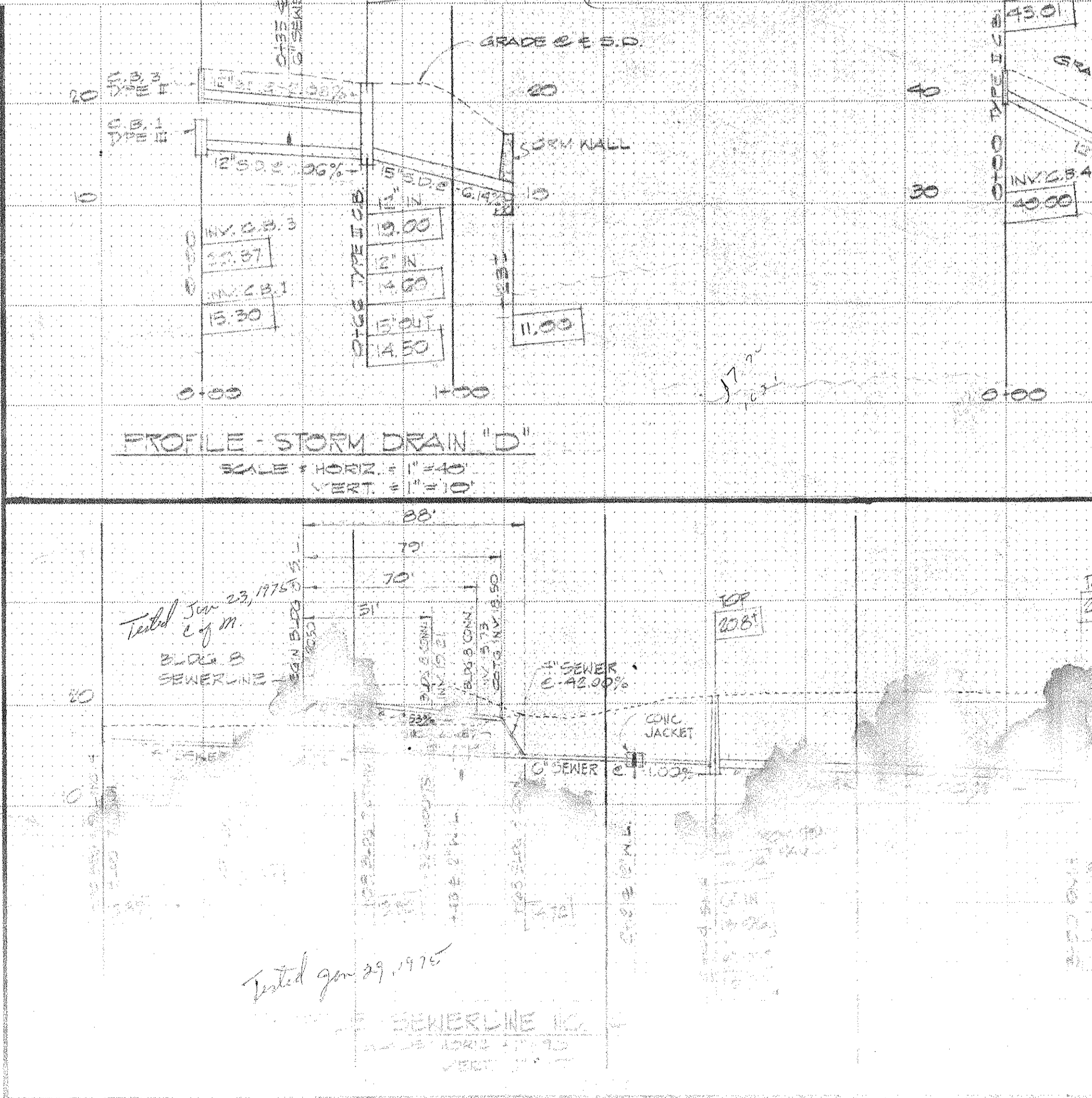
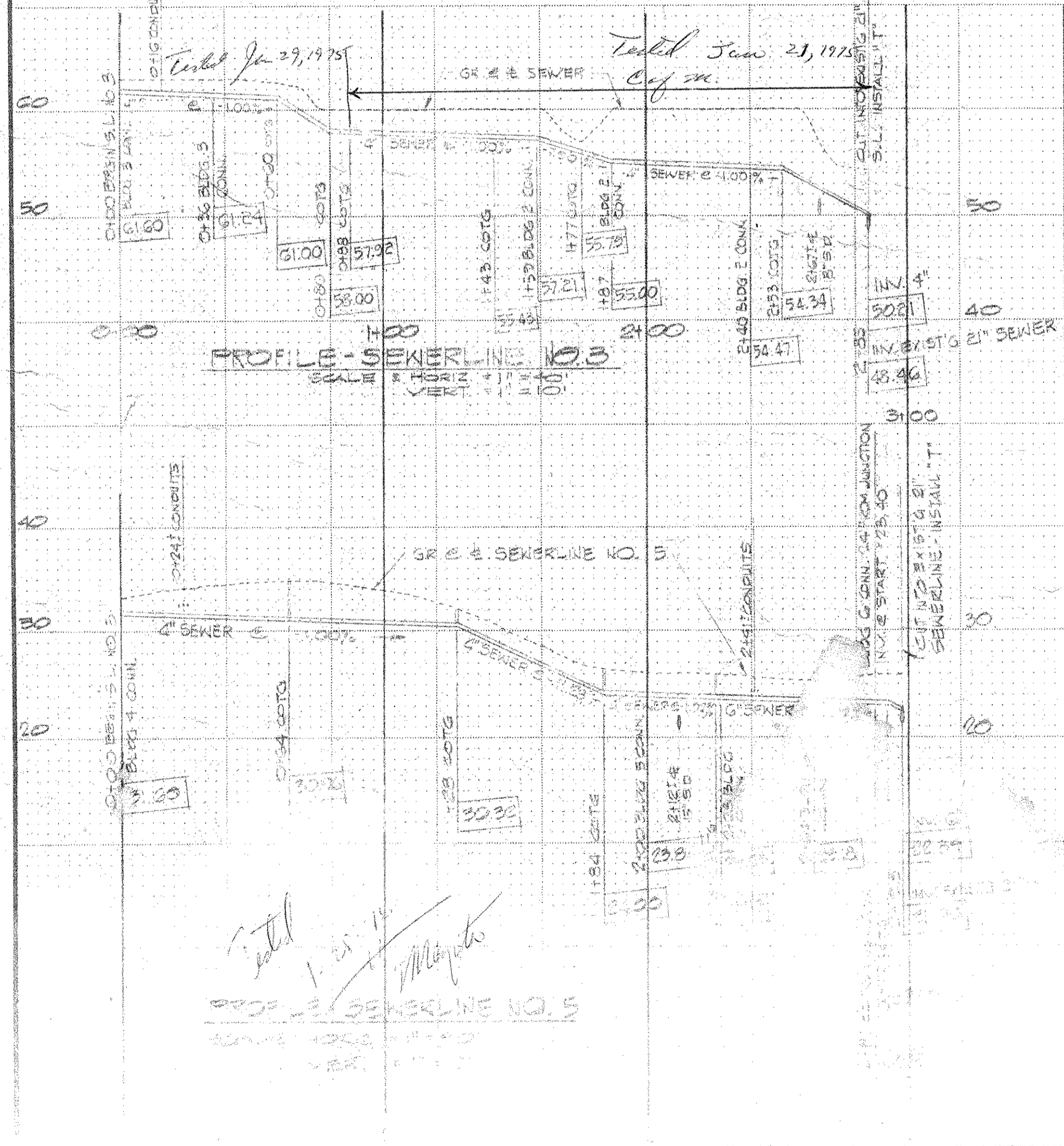

CONSTRUCTION
DRAWING REVISIONS
FINAL REVIEW
DATE

Norman Sallo Engineering Consultants, Inc.
 Civil Engineers
 P.O. Box L
 Wailea, Hawaii 96793
 (808) 244-5275

Eshelock Hornsey Dodge and Davis
 Architects and Planners
 120 Glen Street
 San Francisco, California 94111
 (415) 421-1924

Hahn, Riecke, AIA
 Architect Associated
 Kalaheo, Hawaii 96923

Wailea
 KEAWAKAPU BEACH VILLAGE
 MAUI, HAWAII
 WAILEA DEVELOPMENT COMPANY
 622 BISHOP ST., HONOLULU, HAWAII 96813

TMK: 2-1-8 For 42

TITLE
PLAN & PROFILE
STORM DRAIN AND SEWER LINE
SERVING BLDGS 1 THRU 11
SCALE
AS SHOWN

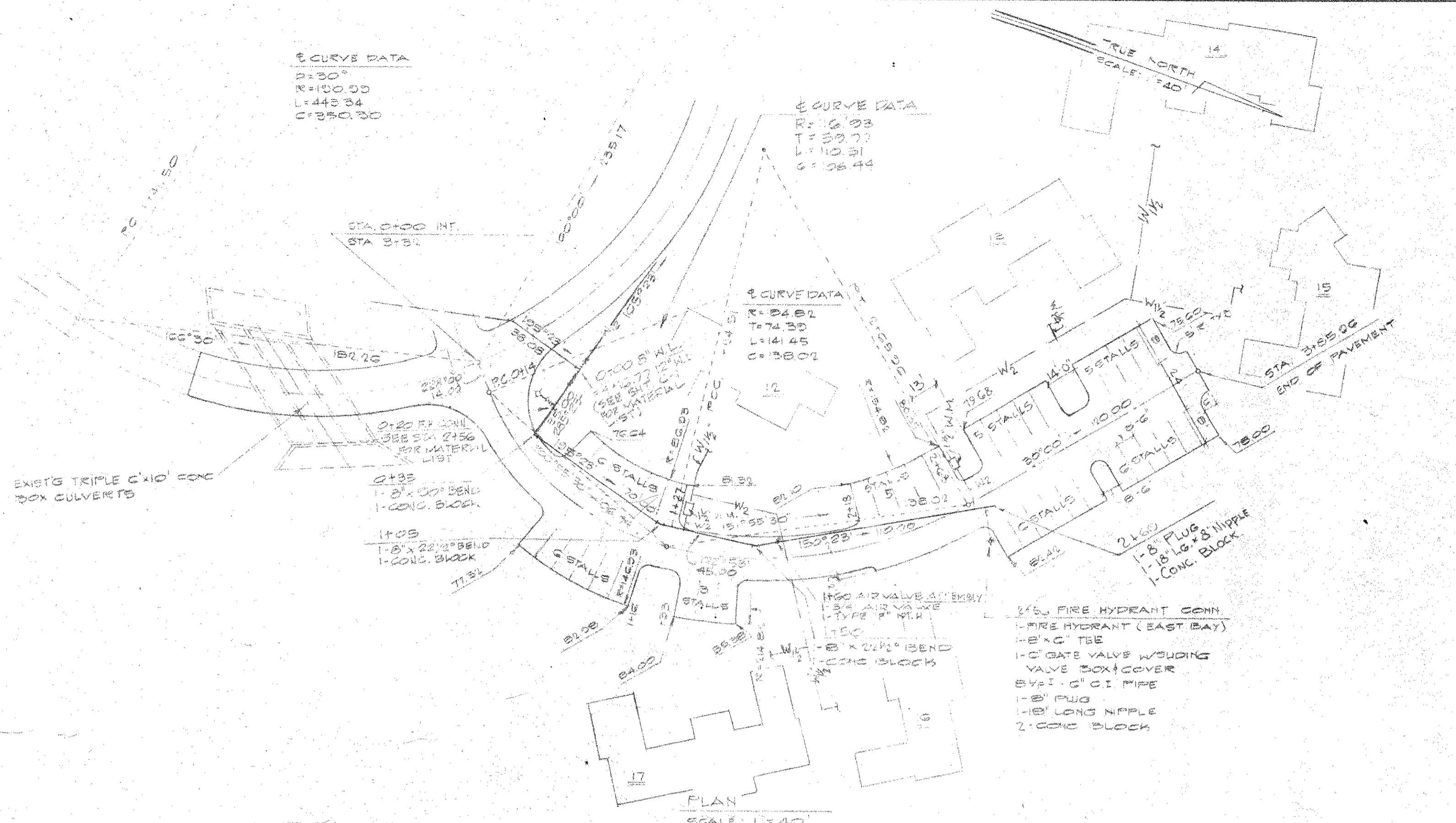

REVISED 7/22/74 AS
DICTATED BY PRE-CONSTRUCTION
MEETING OF 7/11/74

REVISED FOR
CONSTRUCTION
6/24/74

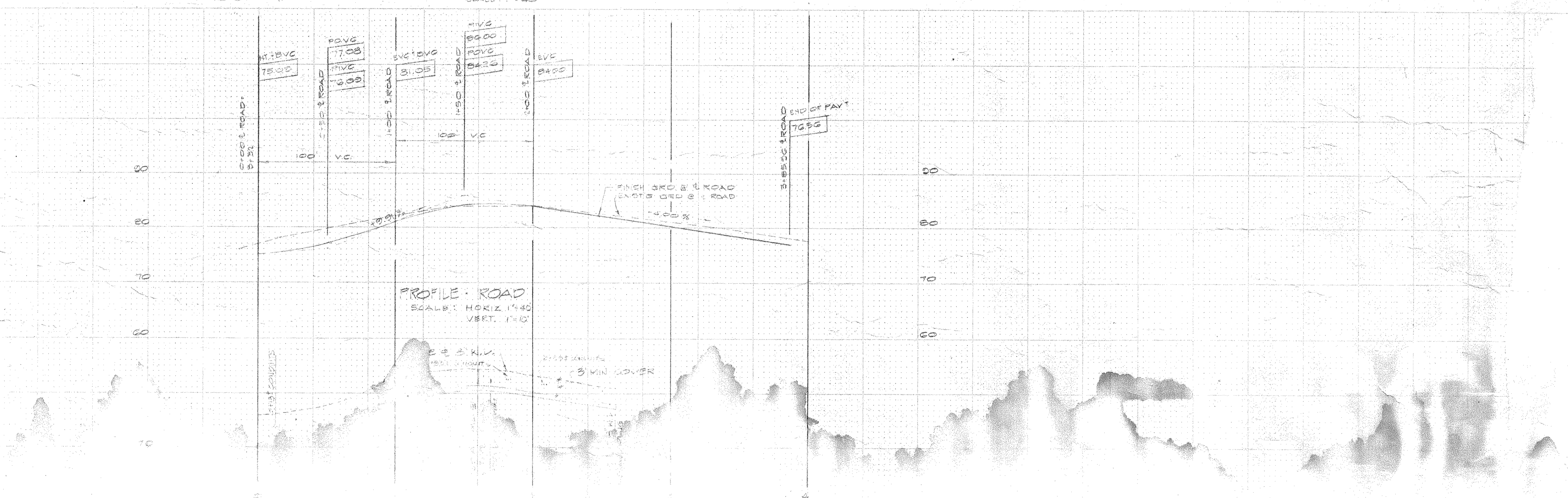

Norman Saito Engineering Consultants, Inc.
Civil Engineers
P. O. Box 1
Wailuku, Hawaii 96793
(808) 241-1111

SEALED
CONSTRUCTION
PROJECT: KAWAII COLLEGE
SHEET: R101/102

Esteban Honey Duggan and Davis
Architects and Planners
126 Green Street
San Francisco, California 94111
(415) 421-1924

Hans Riecke, AIA
Architect/Associated
Kenelua, Hawaii 96732

idea CONSULTANTS, INC.
2001 VILLAGE AVENUE
WAILUKU, HAWAII 96793

RECEIVED

DEC 23 1974

LAND USE & CODES ADM.
COUNTY OF MAUI

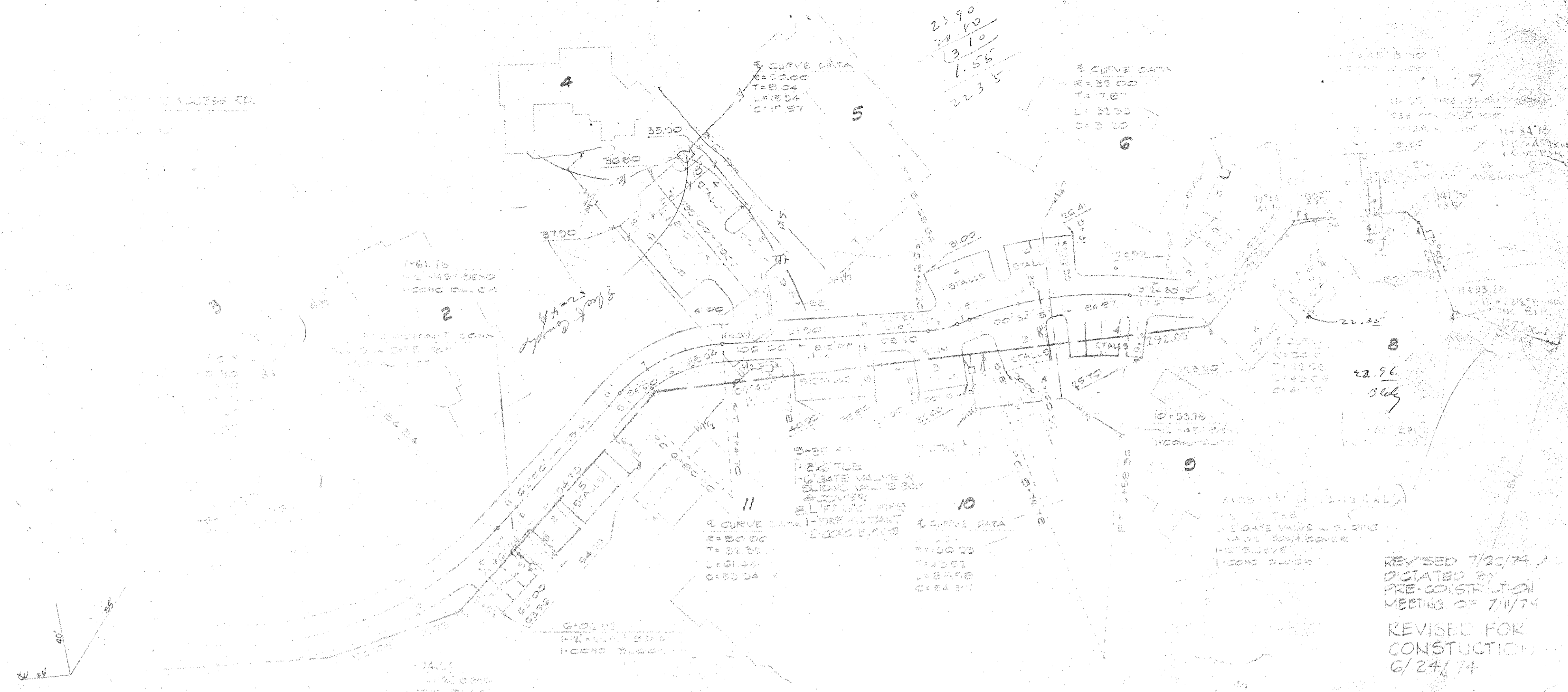

REVISED 7/20/74
 DATED BY
 PRE-CONSTRUCTION
 MEETING 2/7/74
 REVISED FOR
 CONSTRUCTION
 6/24/74

879/425 K...
 52,786, M...
 Phil...

waiver
 Phil...

North-South Engineering Consultants, Inc.
 1145 S. W. ...
 Honolulu, Hawaii